

# INTELLIGENCE IN MOTION



Intelligent design working for you every day in more ways than any other carts can offer. Beginning with lids that are ergonomically designed for easy, safe handling. Lids that are designed to seal in odors and overlap for rain protection. Lids that are sturdy enough not to blow open under windy conditions.

The bar area is another outstanding design feature of the Schaefer cart. It rotates freely for less stress on the cart body. It incorporates a unique self-centering feature for easy assembly and extra wall thickness for strength and durability.

Intelligent design combined with an injection-molding manufacturing process based on strict ISO 9001 guidelines, for the best cart you will ever buy. Schaefer carts in motion in your city, in your neighborhood and on your streets, making your community a better place to live. Contact us for all the advantages Schaefer carts have to offer.

**Schaefer Systems International, Inc.**

P.O. Box 7009  
Charlotte, NC 28241  
Tel: 877-724-2327  
Fax: 704-588-1862  
Email: [general@ssimail.net](mailto:general@ssimail.net)  
[www.ssi.schaefer-us.com](http://www.ssi.schaefer-us.com)

# Schaefer Universal System Design Cart



Model USD-B is for use with standard bar-lock lifters or automated grabbers. Model USD-C is for use with comb lifters or automated grabbers.



- A Body**
- Non-slip, textured finish on corners for grabber efficiency
  - 0.175" or greater wall thickness for durability
  - Long-lasting, integrated lid hinges
  - Smooth surface inside and out for easy maintenance
  - Injection molded for maximum strength and durability
  - One-piece high-density polyethylene (HDPE) construction

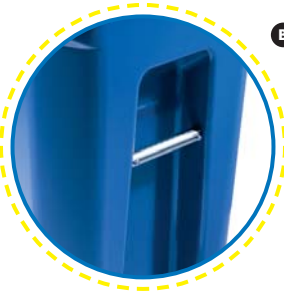

- B Bar**
- Highly durable, in-molded bar supports
  - Freely rotating steel bar for less stress on cart body
  - Unique one-way mounting feature for easy assembly
  - Extra wall thickness in bar area for durability



- C Upper Attachment**
- In-molded, reinforced upper attachment for bar-lock lifters, or
  - In-molded, reinforced frontal rim for comb lifters (USD-C)
  - In-molded support ribs for added strength



- D Lids**
- USD 35
- New, easy open lid design
  - Overlapping lip for rain protection
  - Inside dripping rim to seal in odors
  - 270° lid opening
  - Options include:
    - front-mounted paper slot
    - side-mounted ventilation for yard waste



- USD 65 & USD 95
- Overlapping lip for rain protection
  - Inside dripping rim to seal in odors
  - 270° lid opening
  - Sturdy, comfortable ergonomic handles

- E Handles**
- In-molded, integral hand grips for pushing/pulling the cart
  - Smooth surface with no protrusions
  - 2" x 5" opening for easy gripping

- F Wheels & Axles**
- 0.875" axle of tempered, rolled, cut, galvanized solid steel
  - Maintenance-free bearings lubricated for life
  - 12" wheels on 95-gallon model
  - 10" wheels on 65-gallon model

- G Bottom**
- In-molded toe hold to ease tilting of loaded cart
  - 0.375" wear strip for longer life

- H Colors & Marking**
- Available in green, blue, brown and charcoal
  - Custom colors available
  - Smooth surface for hot stamping on lid and body



▲ 5-gallon insert in 65-gallon container for recycling glass



▲ 20-gallon insert in 35-gallon container for collection of recyclables and organics

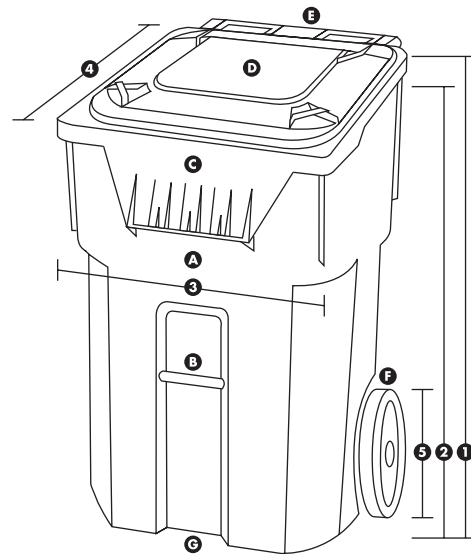

UNIVERSAL SYSTEM DESIGN CART						
(measurements in inches, unless specified)						
ORDER #	DIMENSIONS				WHEEL DIAMETER	LOAD RATING
	1 H	2 H CART BODY	3 W	4 D		
						LBS.
USD 35	38.2	35.8	22.8	22.3	8	125
USD 65	42.2	39.5	25.9	26.5	10	220
USD 95	46.1	42.8	27.7	31.6	12	340

ANSI Z245.30 and ANSI Z245.60 Approved  
ISO 9001 Certified