



**KOMPTECH<sup>®</sup>**

Technology for a better environment

# Hurrikan

Mobile and stationary windsifter



# Hurrikan - Windsifter



## INTRODUCTION

Cleaning stages during the production of quality compost are indispensable.

Screening at the end of the rotting process generates a usable fraction and a screen overflow. This is again perfect for use as structure material. Use of these woody fractions as biomass fuel is also conceivable, provided however that as many spurious contraries as possible (mainly light material such as plastic, foils, paper, etc.) have been removed.

The Hurrikan and Hurrikan S wind sifters from Komptech are a benchmark in this sector. The patented "pressure-suction" process ensures an excellent degree of selectivity and cleaning. The quality of the recyclable over-sized particles can be improved yet further by using magnet separation and separation of rolling objects.

### Highlights

- at high throughputs more than 90% selectivity can be achieved by precise adjustment of settings to material properties
- high-performance S-version with enlarged suction section (two suction blowers)
- available as mobile version with integrated diesel generator or as electrically driven stationary version
- compatible with most commercially available mobile screening units

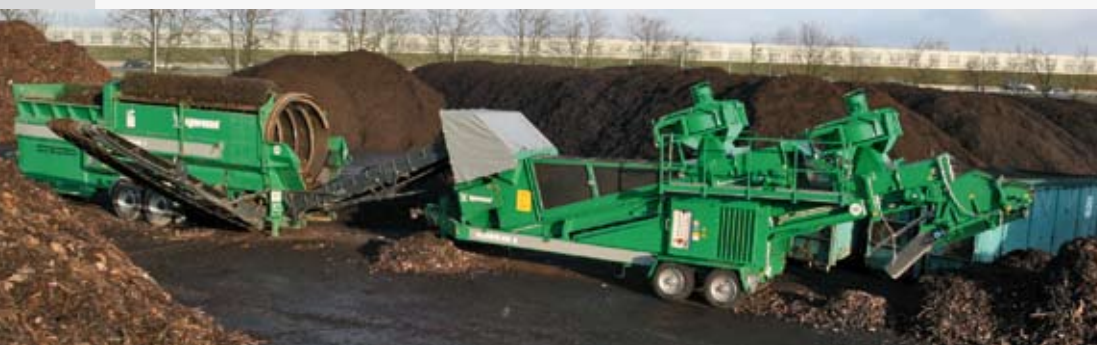

# APPLICATION



Screening residue from composting



Woody biomass for fuel production



Special application e.g. roofing shingles

# FUNCTION

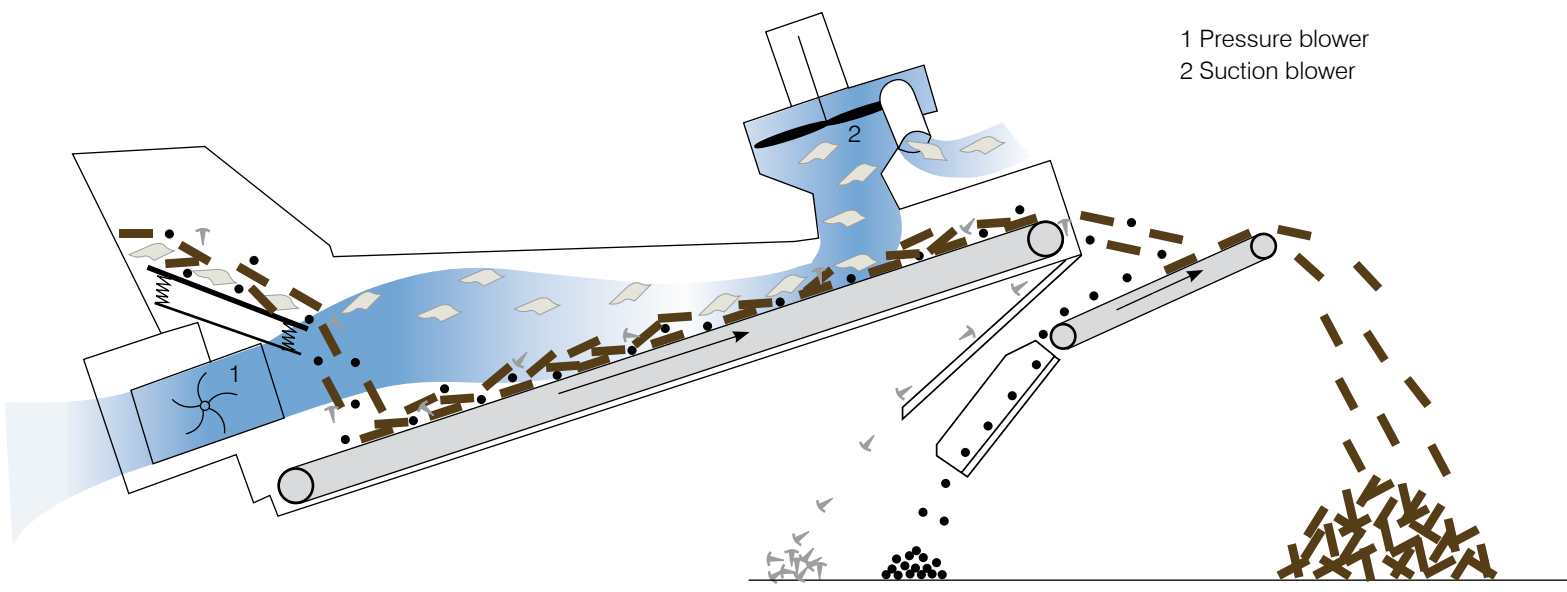

The patented “pressure-suction” process enables an effective separation of light fraction contaminants from screening residues. In the first step, light fraction contaminants are separated from screened heavier over’s material by a pressure blower (1). The material flow moving towards the suction blower (2) is then comprised of screened over’s material on the bottom with light contaminants on top. In the second step, the lightweight material is removed and drawn off by the suction blower and the contaminants are deposited into a separate container. This suction process takes place twice in succession on the Hurrikan S, increasing throughput capabilities and offering a greater degree of separation. When configured with a stone trap and magnet drum, the Hurrikan becomes the perfect cleaner.

# Hurrikan - Windsifter



## Air intake

- Special intake channels for rough conditions as option



## Vibrating feeder

- For material opening



## Pressure and suction blower

- Foldable for servicing, hydraulically foldable as option



## Servicing platform (option)

- For easy accessibility (only in combination with hydraulically foldable suction blower)

The Komtech brand is synonymous with quality, reliability and stability in product value. This means that only premier quality sourced components are used alongside components manufactured in-house.

## Vibrating feed chute

The stainless steel intake chute also serves as a vibrating feed chute to allow for even material flow. The wide chute allows the Hurrikan to be used in conjunction with all popular screen machines on the market and will accept oversize fraction conveyor belts up to 3' 11" wide with a feed height from 6'5" to 7' 5". The angle of the vibrating feed chute can be adjusted depending on material. The vibration motor drive unit is rated at 0.8 kW. An enclosure for the chute, made of sturdy truck tarpaulin, is available as an option to prevent material from blowing everywhere.

## Pressure and suction blower

A radial blower with a drive rating of 7.5 kW is used to generate a flow of compressed air. For rough operating conditions, special suction channels are available as an option with intake channels installed upwards alongside the vibrating feeder.

The suction and feed blowers, (2 on the S version) rated at 15 kW have a specially designed blower rotor with wear plates that guarantee smooth throughput. The blower is foldable upwards for service work. Hydraulic flaps are also available as an option – with a service platform including a ladder for easy accessibility.

Separation belt for rolling fraction

Magnet drum

Diesel generator

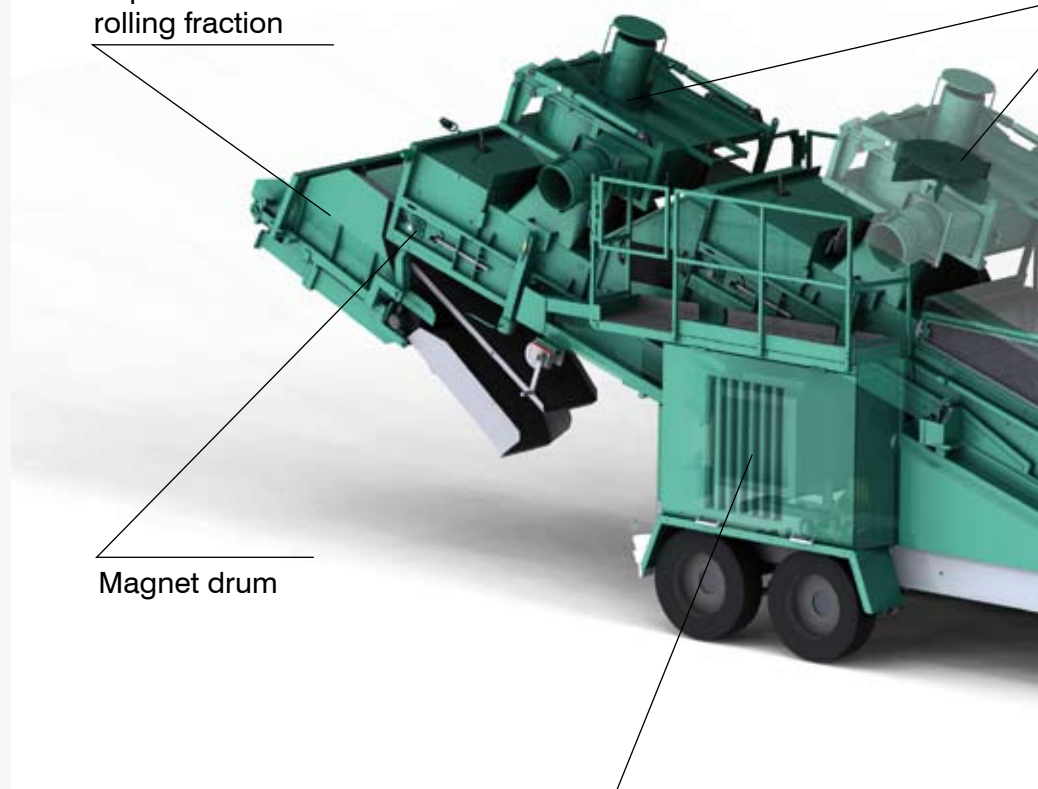

# MACHINE WALKABOUT

## Chassis

The standard design of the windsifter is a central axle trailer (tandem axle on the S version) conforming to road traffic licensing regulations.

## Diesel generator (option)

A power unit, available as an accessory, lends the windsifter complete independence from the power supply. A Perkins turbo diesel motor with a generator rated at 53 kVA (66 kVA on the S version) is integrated compactly into the frame without changing the machine dimensions. Also included is a motor monitoring unit that protects the motor from overloading.

The S version also has the option of a power socket for external energy supply.

## Magnet drum (option)

The drive drum of the discharge conveyor belt is replaced by a powerful permanent magnet drum. Metals separated off are discharged into a collection vessel via a transport chute. The upgrade of the Hurrikan to an effective magnetic separator can also be performed later at any time.

## Separation belt for rolling fraction (option)

The principle of separation is based on the rolling properties of different forms. This is achieved by an additional, short conveyor belt on the discharge side. On the tiltable conveyor belt, round, heavy objects (mainly stones) roll downwards and are diverted via a chute.

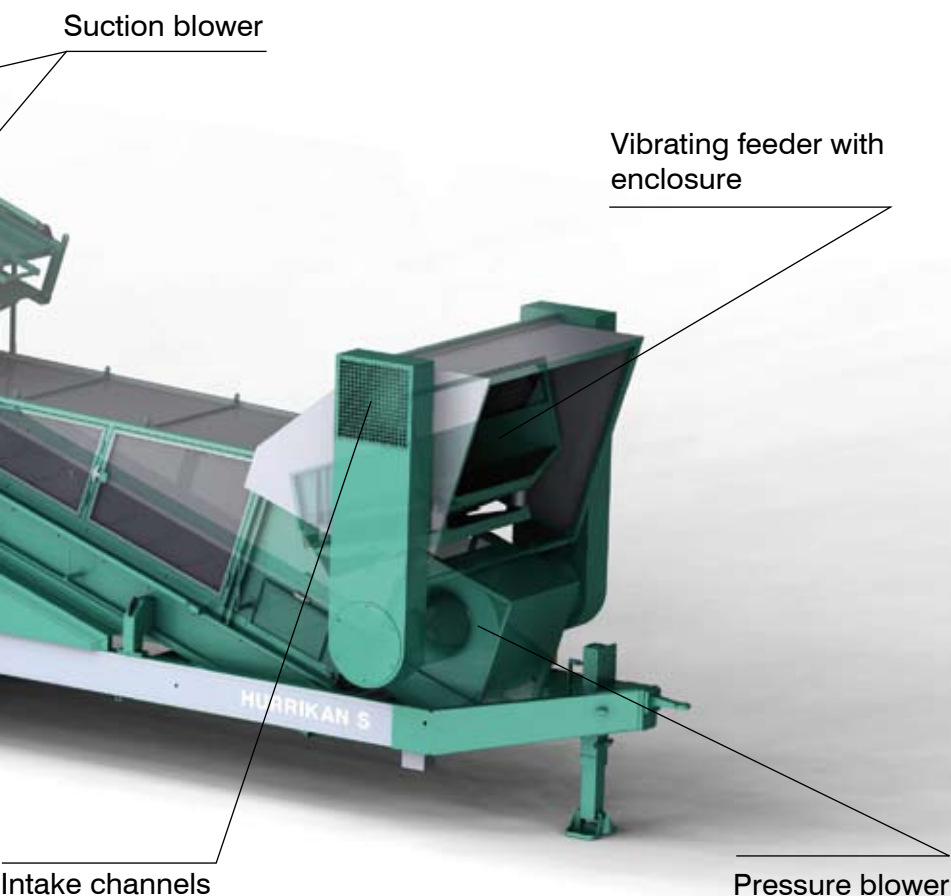

## Chassis

- Central axle trailer



## Diesel generator (option)

- For independence from the power supply



## Magnet drum (option)

- Permanent magnet drum with effective Fe-separation



## Separation belt for rolling fraction (option)

- removes rolling contaminants (stones)

# Hurrikan - Windsifter



## MOBILE AND STATIONARY

Mobile and stationary variants are available for both Hurrikan and Hurrikan S.

### Mobile version

The mobile machine is easy to transport, quick to deploy and, with a generator, also independent from power supply.

### Stationary version

For wind sifting, the stationary Hurrikan unit has extremely compact dimensions and can therefore be easily integrated into a system chain.



# TECHNICAL SPECIFICATION

	Hurrikan	Hurrikan S
<b>Drive</b>		
Power input:	28 kW / 38 HP	47 kW / 64 HP
Diesel generator:	48 kVA / 51 HP	60 kVA / 81 HP
Vibrating feeder:	0,8 kW / 1 HP	0,8 kW / 1 HP
Pressure blower:	7,5 kW / 9 HP	7,5 kW / 9 HP
Suction and feed blower:	15 kW / 20 HP	2 x 15 kW / 2 x 20 HP
<b>Machinedimensions</b>		
Length x width x height		
Transport position:	27' 3" x 8' 4" x 13' 1"	36' 1" x 8' 4" x 13' 1"
Length with roll separator:	30' 2"	38' 9"
Length conveyor belt:	19'	19' (Separation 1)
(Axle to axle distance)		9' 2" (Separation 2)
<b>Weight</b>	14,330 lbs.	22,046 lbs.
<b>Feed</b>		
Width feed belt:	to 3' 11"	to 3' 11"
Feed height:	adjustable from 6' 5" to 7' 5"	adjustable from 6' 5" to 7' 5"
<b>Throughput</b> (dependent on material)	to 52 yd <sup>3</sup> /h	to 78 yd <sup>3</sup> /h

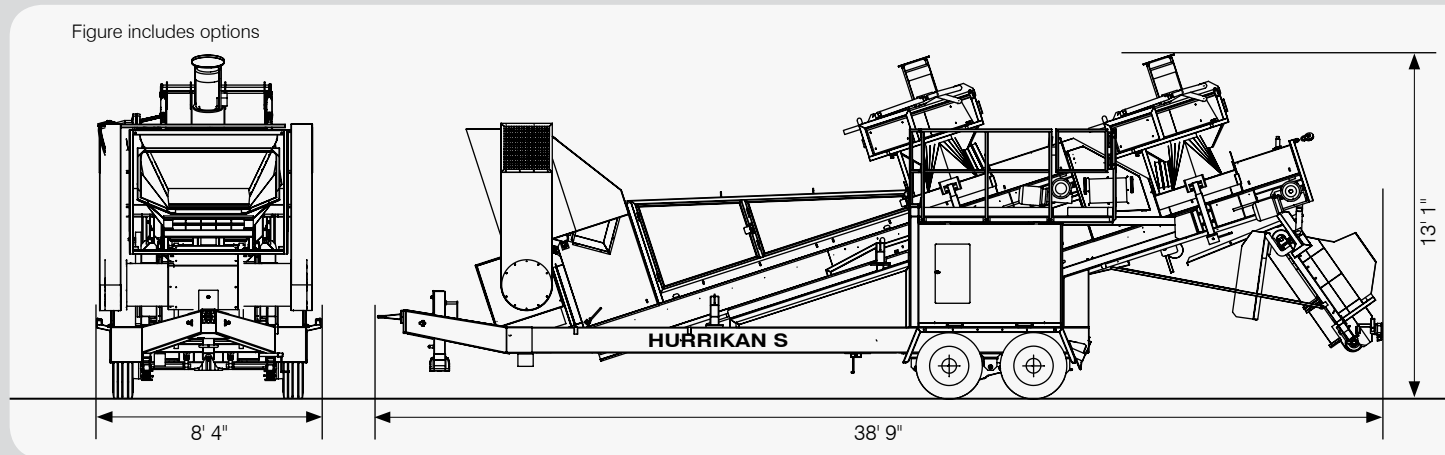
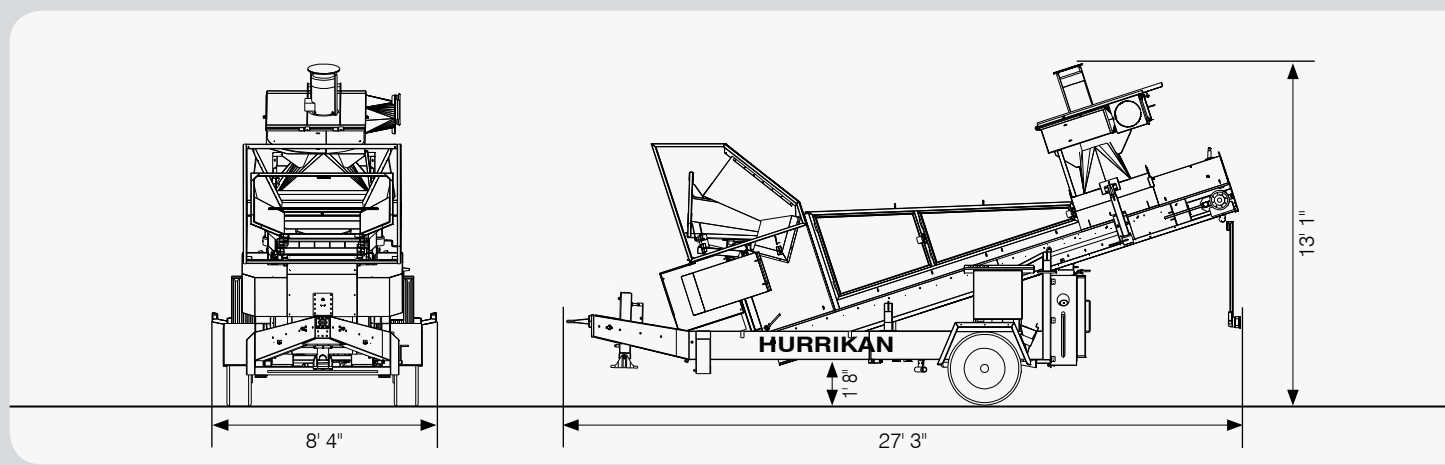

Technology for a better environment

Komptech USA Inc.  
[t] 720 - 890 - 9090  
[f] 720 - 890 - 5907  
[e] info@komptechusa.com

[www.komptechusa.com](http://www.komptechusa.com)

We reserve the right to make technical changes due to ongoing development. USA\_102010